

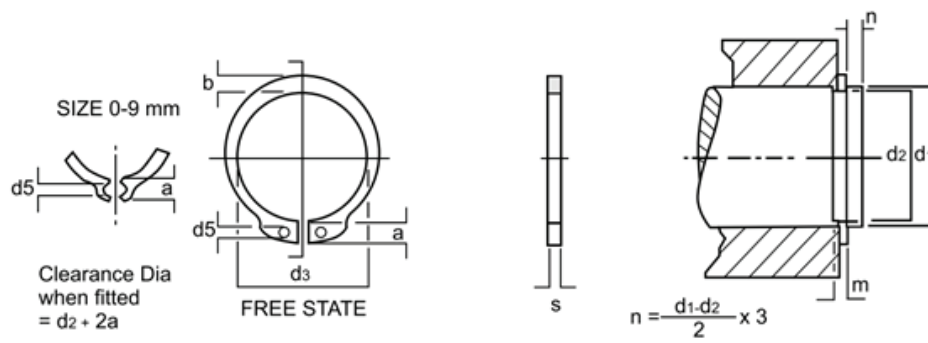

# Cathect Engineering Co.

Circlips | Washers | Dowel Pin | Sheet Metal Components



Material: Carbon Spring Steel

Finish: Phosphating or as per Requirements

Hardness: d1 - 3 to 47mm : 47 to 54 HRC

d1 - 48 to 200mm : 44 to 51 HRC

d1 - 200 to 300mm : 39 to 47 HRC

shall Dia, d1 Nom. Size	Circlips						Groove					
	s		d3		a	b <sup>d</sup>	d <sub>5</sub>	d2t		mt	t	n
	Size	Tolerance	Size	Tolerance	Max.	μ	Min.	size	Tolerance	H13		Min
3	0.4	± 0.02	2.7	+0.04 -0.15	1.9	0.8	1	2.8	0+0.04 (H10)	0.5	0.1	0.3
4	0.4		3.7		2.2	0.9	1	3.8	0-0.048 (H10)	0.5	0.1	0.3
5	0.6	± 0.03	4.7	+0.06 -0.18	2.5	1.1	1	4.8	0-0.06 (H10)	0.7	0.1	0.3
6	0.7		5.6		2.7	1.3	1.2	5.7		0.8	0.15	0.5
7	0.8		6.5		3.1	1.4	1.2	6.7		0.9	0.15	0.5
8	0.8	± 0.04	7.4	+0.10 -0.36	3.2	1.5	1.2	7.6	0-0.11 (H11)	0.9	0.2	0.6
9	1		8.4		3.3	1.7	1.2	8.6		1.1	0.2	0.6
10	1		9.3		3.3	1.8	1.5	9.6		1.1	0.2	0.6
11	1		10.2		3.3	1.8	1.7	11.5		1.1	0.25	0.8
12	1		11		3.3	1.8	1.7	11.5		1.1	0.25	0.9
13	1		11.9		3.4	2	1.7	12.4		1.1	0.3	0.9
14	1		12.9		3.5	2.1	1.7	13.4		1.1	0.3	0.9
15	1		13.8		3.6	2.2	1.7	14.3		1.1	0.35	1.1
16	1		14.7		3.7	2.3	1.7	15.2		1.1	0.4	1.2
17	1		15.7		3.8	2.3	1.7	16.2		1.1	0.4	1.2
18	1.2	± 0.04	16.5	+0.13 -0.42	3.9	2.4	2	17	0-0.13 (H11)	1.3	0.5	1.5
19	1.2		17.5		3.9	2.5	2	18		1.3	0.5	1.5
20	1.2		18.5		4	2.6	2	19		1.3	0.5	1.5
21	1.2	± 0.05	19.5	+0.41 -0.42	4.1	2.7	2	20	0-0.21 (H12)	1.3	0.5	1.5
22	1.2		20.5		4.2	2.8	2	21		1.3	0.5	1.5
24	1.2		22.2		4.4	3	2	22.9		1.3	0.55	1.7
25	1.2		23.2		4.4	3	2	24.9		1.3	0.55	1.7
26	1.2		24.2		4.5	3.1	2	24.9		1.3	0.55	1.7
28	1.5		25.9		4.7	3.2	2	26.6		1.6	0.7	2.1
29	1.5		26.9		4.8	3.4	2	27.6		1.6	0.7	2.1
30	1.5		27.9		5	3.5	2	28.6		1.6	0.7	2.1
32	1.5		29.6		5.2	3.6	2.5	30.3		1.6	0.85	2.6
34	1.5		31.5		5.4	3.8	2.5	31.3		1.6	0.85	2.6



shall Dia, d1 Nom. Size	Circlips							Groove					
	s		d3		a	b <sup>d</sup>	d	d2t		mt	t	n	
	Size	Tolerance	Size	Tolerance	Max.	±	Min.	size	Tolerance	H13		Min	
35	1.5	± 0.05	32.2	+0.25 -0.5	5.6	3.9	2.5	33	0-0.25 (H12)	1.6	1	3	
36	1.75		33.2		5.6	4	2.5	34		1.85	1	3	
38	1.75		35.2		5.8	4.2	2.5	36		1.85	1	3	
40	1.75		36.5	+0.39 -0.9	6	4.4	2.5	37.5		1.85	1.25	3.8	
42	1.75		38.5		6.5	4.5	2.5	39.5		1.85	1.25	3.8	
45	1.75		41.5		5.7	4.7	2	52.5		1.85	1.25	3.8	
48	1.75		44.5		6.9	5	2.5	45.5		1.85	1.25	3.8	
50	2		45.8		7	5.1	2.5	47		2.15	1.5	4.5	
52	2	±0.06	47.8	+0.46 -1.1	7.2	5.2	2.5	49	0-0.30 (H12)	2.15	1.5	4.5	
55	2		50.8		7.3	5.4	2.5	52		2.15	1.5	4.5	
56	2		51.8		7.3	5.5	2.5	53		2.15	1.5	4.5	
58	2		53.8		7.4	5.6	2.5	55		2.15	1.5	4.5	
60	2		55.8		7.5	5.8	2.5	57		2.15	1.5	4.5	
62	2		57.8		7.6	6	2.5	59		2.15	1.5	4.5	
63	2		58.8		7.8	6.2	2.5	60		2.15	1.5	4.5	
65	2.5		60.8		7.8	6.3	3	62		2.65	1.5	4.5	
68	2.5		63.5		8	6.5	3	65		2.65	1.5	4.5	
70	2.5		65.5		+0.46 -1.1	8.1	6.6	3		67	0 -0. (H12)	2.65	1.5
72	2.5	67.5	8.2	6.8		3	69	2.65	1.5	4.5			
75	2.5	70.5	8.4	7		3	72	2.65	1.5	4.5			
78	2.5	73.5	8.6	7.3		3	75	2.65	1.5	4.5			
80	2.5	74.5	8.6	7.4		3	76.5	2.65	1.75	5.3			
82	2.5	76.5	8.7	7.6		3	78.5	2.65	1.75	5.3			
85	3	79.5	8.7	7.8		3.5	81.5	2.15	1.75	5.3			
88	3	82.5	± 0.7	8.7		8	3.5	84.5	0 -0.35 (H12)	3.15		1.75	5.3
90	3	84.5		8.8	8.2	3.5	86.5	3.15		1.75	5.3		
95	3	89.5		9.4	8.6	3.5	91.5	3.15		1.75	5.3		
100	3	94.5		9.6	9	3.5	96.5	3.15		1.75	5.3		
105	4	98		± 0.8	9.9	9.3	3.5	101		0 -0.54 (H13)	4.15	2	6
110	4	103			10.1	9.6	3.5	106			4.15	2	6
115	4	108			10.6	9.8	3.5	111			4.15	2	6
120	4	113			11	10.2	3.5	116			4.15	2	6
125	4	118			11.4	10.4	4	121			4.15	2	6
130	4	123			11.6	10.7	4	126			4.15	2	6
135	4	128	11.8		11	4	131	4.15	2		6		
140	4	133	12		11.2	4	136	4.15	2		6		
145	4	138	12.2		11.5	4	141	4.15	2		6		
150	4	142	±0.63 -1.5		13	11.8	4	145	0 -0.63 (H13)		4.15	2.5	7.5
155	4	146		13	12	4	150	4.15		2.5	7.5		
160	4	151		13.3	12.2	4	155	4.15		2.5	7.5		
165	4	155.5		13.5	12.5	4	160	4.15		2.5	7.5		
170	4	160.5		13.5	12.9	4	165	4.15		2.5	7.5		
175	4	165.5		13.5	12.9	4	170	4.15		2.5	7.5		
180	4	170.5		14.2	13.5	4	175	4.15		2.5	7.5		
185	4	175.5		14.2	13.5	4	180	4.15		2.5	7.5		
190	4	180.5		14.2	14	4	185	4.15		2.5	7.5		



shall Dia, d1 Nom. Size	Circlips							Groove				
	s		d3		a	b <sup>d</sup>	d <sub>5</sub>	d2t		mt	t	n
	Size	Tolerance	Size	Tolerance	Max.	r	Min.	size	Tolerance	H13		Min
195	4	± 0.9	185.5	+0.72 -1.7	14.2	14	4	190	0 -0.81 (H13)	4.15	2.5	7.5
200	4		190.5		14.2	14	4	195		4.15	2.5	7.5
210	5		198		14.2	14	4	204		5.15	3	9
220	5		208		14.2	14	4	214		5.15	3	9
230	5		218		14.2	14	4	224		5.15	3	9
240	5		228		14.2	14	4	234		5.15	3	9
250	5		238		14.2	14	4	244		5.15	3	9
260	5		245	+0.13 -0.42	16.2	16	5	252	0 -0.11 (H11)	5.15	4	12
270	5		255		16.2	16	5	262		5.15	4	12
280	5		265		16.2	16	5	272		5.15	4	12
290	5		275		16.2	16	5	282		5.15	4	12
300	5		285		16.2	16	5	292		5.15	4	12

Heavy Pattern: IS 3075

15	1.5	± 0.5	13.8	+0.25 -0.5	4.8	2.4	2	14.3	0 -0.13 (H11)	1.6	0.35	1.1
16	1.5		14.7		5	2.5	2	15.2		1.6	0.4	1.2
17	1.5		15.7		5	2.6	2	16.2		1.6	0.4	1.2
18	1.5		16.5	5.1	2.7	2	17	1.6		0.5	1.5	
20	1.75		18.5	5.5	3	2	19	1.85		0.5	1.5	
22	1.75		20.5	6	3.1	2	21	1.85		0.5	1.5	
24	1.75	22.2	± 0.6	+0.39 -0.9	6.3	3.2	2	22.9	0 -0.21 (H12)	1.85	0.55	1.7
25	2	23.2			6.4	3.4	2	23.9		2.15	0.55	1.7
28	2	25.9			6.5	3.5	2	26.9		2.15	0.7	2.1
30	2	27.9			6.5	4.1	2	28.6		2.15	0.7	2.1
32	2	29.6			6.5	4.1	2.5	30.3		2.15	0.85	2.6
34	2.5	31.5			6.6	4.2	2.5	32.3		2.65	0.85	2.6
35	2.5	32.2	± 0.7	+0.46 -1.1	6.7	4.2	2.5	33	0 -0.25 (H12)	2.65	1	3
38	2.5	35.2			6.8	4.3	2.5	36		2.65	1	3
40	2.5	36.5			7	4.4	2.5	37.5		2.65	1.25	3.8
42	2.5	38.5			7.2	4.5	2.5	39.5		2.65	1.25	3.8
45	2.5	41.5			7.5	4.7	2.5	42.5		2.65	1.25	3.8
48	2.5	44.5			7.8	5	2.5	45.5		2.65	1.25	3.8
50	3	45.8	± 0.8	+0.54 -1.3	8	5.1	2.5	47	0 -0.30 (H12)	3.15	1.5	4.5
52	3	47.8			8.2	5.2	2.5	49		3.15	1.5	4.5
55	3	50.8			8.5	5.4	2.5	52		3.15	1.5	4.5
58	3	53.8			8.8	5.6	2.5	55		3.15	1.5	4.5
60	3	55.8			9	5.8	2.5	57		3.15	1.5	4.5
65	4	60.8			9.3	6.3	3	62		4.15	1.5	4.5
70	4	65.5	9.5	6.6	3	67	4.15	1.5	4.5			
75	4	70.5	9.7	7	3	72	4.15	1.5	4.5			
80	4	74.5	9.8	7.4	3	76.5	4.15	1.75	5.3			
85	4	79.5	10	7.8	3.5	81.5	4.15	1.75	5.3			
90	4	84.5	10.2	8.2	3.5	86.5	4.15	1.75	5.3			
100	4	94.5	10.5	9	3.5	96.5	4.15	1.75	5.3			

# Inverted External Circlip – J Type – DIN 5108, M1408

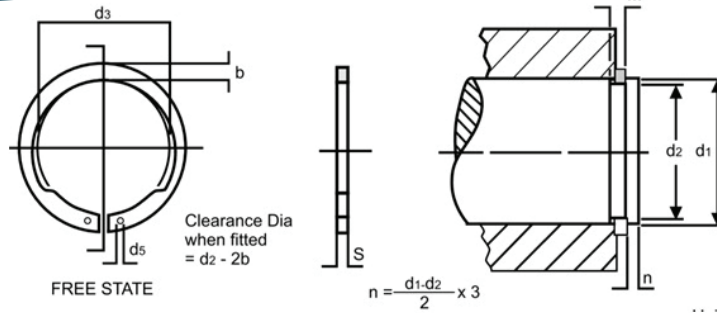

Material: Carbon Spring Steel

Finish: Phosphating or as per requirements

Hardness: d1 - 8 to 48mm : 47 to 54HRC

d1 - 48 to 200mm : 44 to 51HRC

d1 - 200 to 300mm : 40 to 47HRC

Nominal Dia. (d1)	Thickness (S)	Tolerance	Unst. Diam. (d3)	Tolerance	Beam	Lug Hole (d5) min	Groove Diameter (d2)	Toleran.	Groove Width (m)	Rad. Dep of Groove (t)
12	1.00	- 0.06	11.00	+0.10 -0.36	2.1	1.3	11.5	-0.11	1.10	0.25
13	1.00		11.90		2.1	1.3	12.4		1.10	0.30
14	1.00		12.90		2.1	1.3	13.4		1.10	0.30
15	1.00		13.80		2.1	1.3	14.3		1.10	0.35
16	1.00		14.70		2.3	1.3	15.2		1.10	0.40
17	1.00		15.70		2.4	1.3	16.2		1.10	0.40
18	1.20		16.50		2.6	1.5	17.0		1.30	0.50
20	1.20	- 0.06	18.50	+0.13 -0.42	2.8	1.5	19.0	-0.15	1.30	0.50
21	1.20		19.35		2.8	1.5	20.0		1.30	0.50
22	1.20		20.50		3.0	1.5	21.0		1.30	0.50
23	1.20		21.50		3.1	1.5	22.0		1.30	0.50
24	1.20		22.20		3.2	1.5	22.9		1.30	0.55
25	1.20		23.20		3.4	1.5	23.9		1.30	0.55
26	1.50		24.20		3.5	1.5	24.9		1.30	0.55
28	1.50	- 0.06	25.90	+0.21 -0.42	3.8	1.5	26.6	-0.15	1.60	0.75
30	1.50		27.90		3.9	2.0	28.6		1.60	0.75
32	1.50		29.60		4.0	2.0	30.3		1.60	0.85
34	1.50		31.50		3.5	2.0	32.3		1.60	0.85
35	1.75		32.20		4.2	2.0	33.0		1.60	1.10
38	1.75		34.50		4.5	2.0	35.8		1.85	1.20
40	1.75		34.50		4.7	2.0	39.5		1.85	1.25
42	1.75	- 0.07	38.50	+0.39 -0.90	4.7	2.0	42.5	-0.25	1.85	1.25
45	1.75		41.50		4.7	2.0	44.5		1.85	1.25
47	1.75		43.50		5.0	2.0	45.5		1.85	1.25
48	2.00		44.50		5.2	2.0	47.0		1.85	1.25
50	2.00		45.80		5.2	2.5	52.0		2.15	1.50
55	2.00		50.80		5.8	2.5	55.0		2.15	1.50
58	2.00		53.80		5.8	2.5	57.0		2.15	1.50
60	2.50	55.80	5.8	2.5	62.0	2.15	1.50			
65	2.50	- 0.07	60.80	+0.46 -1.10	6.0	2.5	67.0	-0.25	2.65	1.50
70	2.50		65.50		6.5	2.5	69.0		2.65	1.50
72	2.50		67.50		6.5	2.5	72.0		2.65	1.50
72	2.50		67.50		6.5	2.5	69.0		2.65	1.50
75	2.50		70.50		6.5	2.5	72.0		2.65	1.50



Nominal Dia. (d1)	Thickness (S)	Tolerance	Unst. Diam. (d3)	Tolerance	Beam	Lug Hole(d5) min	Groove Diameter (d2)	Toleran.	Groove Width (m)	Rad.Dep of Groove (t)
80	2.50	-0.07	74.50	+0.46-1.10	7.0	2.5	76.5	-0.30	2.65	1.75
80	2.50		74.50		7.0	2.5	76.5		2.65	1.75
82	2.50		76.50		7.0	2.5	78.5	-0.35	2.65	1.75
85	3.00	-0.08	79.50	7.4	3.0	81.5	3.15		1.75	
87	3.00		79.50	7.4	3.0	81.5	3.15		1.75	
90	3.00		84.50	+0.54-1.30	7.4	3.0	86.5		3.15	1.75
95	3.00		89.50		8.0	3.0	91.5		3.15	1.75
100	3.00		94.50		8.0	3.0	96.5	3.15	1.75	

# K Type External Circlip – DIN 983

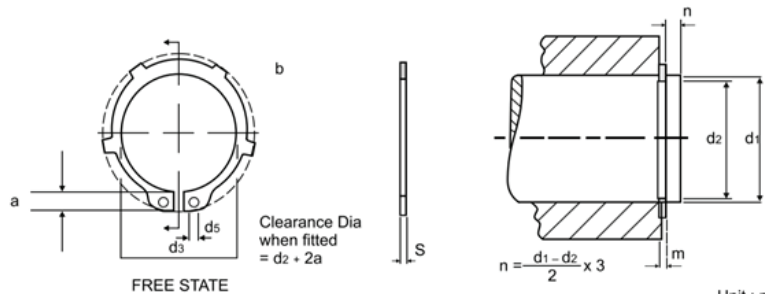

Material: Carbon Spring Steel  
 Hardness: d1 - 16 to 47mm :47 to 54 HRC  
 d1 - 48 to 140mm :44 to 51 HRC

Finish: Phosphating or as per requirements

Shaft dia, d1		Circlip						Groove					
Nominal size	s	Tolera.	d3		a	b	d5	d2		m	t	n	
				Tolera.	max	approx	min		Tolera.	H13		min	
16	1	0 -0.06	14.7	+0.1 -0.36	3.5	2.3	1.7	15.2	0 -0.11	1.1	0.4	1.2	
17	1		15.7		3.6	2.3	1.7	16.2		1.1	0.4	1.2	
18	1.2		16.5		3.7	2.4	2	17		1.3	0.5	1.5	
19	1.2		17.5	3.7	2.5	2	18	1.3	0.5	1.5			
20	1.2		18.5	+0.13 -0.42	3.8	2.6	2	19	0	1.3	0.5	1.5	
22	1.2		20.5		4	2.8	2	21	-0.13	1.3	0.5	1.5	
23	1.2		21.5	+0.21 -0.42	4.1	2.9	2	22	0 -0.21	1.3	0.5	1.5	
24	1.2		22.2		4.2	3	2	22.9		1.3	0.55	1.7	
25	1.2		23.2		4.3	3	2	23.9		1.3	0.55	1.7	
26	1.2		24.2		4.4	3.1	2	24.9		1.3	0.55	1.7	
28	1.5		25.9		4.5	3.2	2	26.6		1.6	0.7	2.1	
30	1.5		27.9		4.7	3.5	2	28.6		1.6	0.7	2.1	
32	1.5		29.6		5	3.6	2.5	30.3		1.6	0.85	2.6	
35	1.5		32.2		0.25 -0.5	5.2	3.9	2.5		33	0 -0.25	1.6	1
38	1.75		35.2	5.5		4.2	2.5	36	1.85	1		3	
40	1.75		36.5	7.2	4.4	2.5	37.5	1.85	1.25	3.8			
42	1.75	38.5	0.39 -0.9	7.2	4.5	2.5	39.5	0 -0.25	1.85	1.25	3.8		
45	1.75	41.5		7.2	4.7	2.5	42.5		1.85	1.25	3.8		
47	1.75	43.5		7.2	4.9	2.5	44.5		1.85	1.25	3.8		
48	1.75	44.5		7.2	5	2.5	45.5		1.85	1.25	3.8		
50	2	45.8	0 -0.07	8.2	5.1	2.5	47	0 -0.3	2.15	1.5	4.5		
55	2	50.8		8.2	5.4	2.5	52		2.15	1.5	4.5		
57	2	52.8		8.2	5.5	2.5	54		2.15	1.5	4.5		
58	2	53.8		8.2	5.6	2.5	55		2.15	1.5	4.5		
60	2	55.8		8.2	5.8	2.5	57		2.15	1.5	4.5		
62	2.5	57.8		0.46 -1.1	8.2	6	2.5		59	0 -0.3	2.15	1.5	4.5
65	2.5	60.8			10.2	6.3	3		62		2.65	1.5	4.5
67	2.5	62.5			10.2	6.4	3		64		2.65	1.5	4.5
68	2.5	63.5			10.2	6.5	3		65		2.65	1.5	4.5
70	2.5	65.5			10.2	6.6	3		67		2.65	1.5	4.5
75	2.5	70.5	10.2		7	3	72	2.65	1.5		4.5		
80	2.5	74.5	10.2		7.4	3	76	2.65	1.75		5.3		
85	3	79.5	0.54 -1.3		10.2	7.8	3.5	81.5	0 -0.35		3.15	1.75	5.3
90	3	84.5		10.2	8.2	3.5	86.5	3.15		1.75	5.3		
95	3	89.5		10.2	8.6	3.5	91.5	3.15		1.75	5.3		
100	3	94.5		10.2	9	3.5	96.5	3.15		1.75	5.3		
110	4	103	0 -0.1	12.2	9.6	3.5	106	0 -0.54	4.15	2	6		
120	4	113		14.2	10.2	3.5	116		4.15	2	6		
130	4	123		14.2	10.7	4	126		4.15	2	6		
140	4	133		14.2	11.2	4	136		-0.63	4.15	2	6	

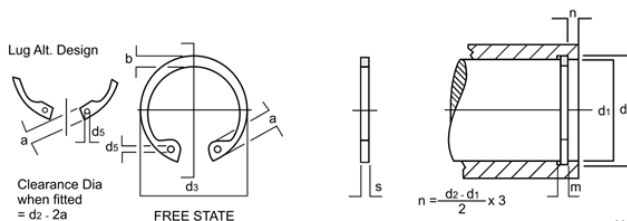

Material: Carbon Spring Steel

Hardness: d1 - 8 to 48mm : 47 to 54HRC

d1 - 48 to 200mm : 44 to 51HRC

d1 - 200 to 300mm : 40 to 47HRc

Finish: Phosphating or as per Requirements Unit: m

shall Dia, d1 Nom. Size	Circlips							Groove				
	s		d3		a	b <sup>d</sup>	d <sub>5</sub>	d2t		mt	t	n
	Size	Tolerranc.	Size	Tolerranc.	Max.	r	Min.	size	Tolerance	H13		Min
8	0.8	± 0.03	8.7	+0.36 -0.10	2.4	1.1	1	8.4	+0.09 0	0.9	0.2	0.6
9	0.8		9.8		2.5	1.3	1	9.4	(H10)	0.9	0.2	0.6
10	1	± 0.04	10.8		3.2	1.4	1.2	10.4	+0.011 0	1.1	0.2	0.6
11	1		11.8		3.3	1.5	1.2	11.4		1.1	0.2	0.6
12	1		13		3.4	1.7	1.5	12.5		1.1	0.25	0.8
13	1		14.1		3.6	1.8	1.5	13.6		1.1	0.3	0.9
14	1		15.1		3.7	1.9	1.7	14.6		1.1	0.3	0.9
15	1		16.2		3.7	2	1.7	15.7	1.1	0.35	1.1	
16	1		17.3		3.8	2	1.7	16.8	1.1	0.4	1.2	
17	1		18.3		3.9	2.1	1.7	17.8	1.1	0.4	1.2	
18	1		19.5	+0.42 -0.13	4.1	2.2	2	19	+0.13 0	1.1	0.5	1.5
19	1		20.5		4.1	2.2	2	20		1.1	0.5	1.5
20	1	21.5	4.2		2.3	2	21	1.1		0.5	1.5	
21	1	22.5	4.2		2.4	2	22	1.1		0.5	1.5	
22	1	23.5	4.2	2.5	2	23	1.1	0.5	1.5			
24	1.2	± 0.05	25.9	+0.42 -0.21	4.4	2.6	2	25.2	+0.21 0	1.3	0.6	1.8
25	1.2		26.9		4.5	2.7	2	26.2		1.3	0.6	1.8
26	1.2		27.9		4.7	2.8	2	27.2		1.3	0.6	1.8
28	1.2		30.1	+0.5 -0.25	4.8	2.9	2	29.4	+0.25 0	1.3	0.7	2.1
30	1.2		32.1		4.8	3	2	31.4		1.3	0.7	2.1
31	1.2		33.4		5.2	3.2	2.5	32.7		1.3	0.85	2.6
32	1.2		34.4		5.4	3.2	2.5	33.7		1.3	0.85	2.6
34	1.5		36.5		5.4	3.3	2.5	35.7		1.6	0.85	2.6
35	1.5		37.8		5.4	3.4	2.5	37		1.6	1	3
36	1.5		38.8		5.4	3.5	2.5	38		1.6	1	3
37	1.5	39.8	5.5	3.6	2.5	39	1.6	1	3			
38	1.5	40.8	5.5	3.7	2.5	40	1.6	1	3			
40	1.75	± 0.06	43.5	+0.9 -0.39	5.8	3.9	2.5	42.5	+0.25 0	1.85	1.25	3.8
42	1.75		45.5		5.9	4.1	2.5	44.5		1.85	1.25	3.8
45	1.75		48.5		6.2	4.3	2.5	47.5		1.85	1.25	3.8
47	1.75		50.5	+0.1 -0.46	6.4	4.4	2.5	49.5	+0.30 0	1.85	1.25	3.8
48	1.75		51.5		6.4	4.5	2.5	50.5		1.85	1.25	3.8
50	2		54.2		6.5	4.6	2.5	53		2.15	1.5	4.5
52	2		56.2		6.7	4.7	2.5	58		2.15	1.5	4.5
55	2		5.92		6.8	5	2.5	58		2.15	1.5	4.5
56	2		6.2		6.8	5.1	2.5	59		2.15	1.5	4.5
58	2		62.2		6.9	5.2	2.5	61		2.15	1.5	4.5
60	2	65.2	7.3	5.4	2.5	63	2.15	1.5	4.5			
62	2	66.2	7.3	5.5	2.5	65	2.15	1.5	4.5			
63	2	67.2	7.3	5.6	2.5	66	2.15	1.5	4.5			
65	2.5	± 0.07	69.2		7.6	5.8	3	68		2.65	1.5	4.5
68	2.5		72.5		7.8	6.1	3	71		2.65	1.5	4.5
70	2.5		74.5		7.8	6.2	3	73		2.65	1.5	4.5
72	2.5		76.5		7.8	6.4	3	75		2.65	1.5	4.5
75	2.5		79.5		7.8	6.6	3	78		2.65	1.5	4.5





shall Dia, d1 Norm. Size	Circlips							Groove							
	s		d3		a	b <sup>d</sup>	d <sub>5</sub>	d2t		mt	t	n			
	Size	Tolerance	Size	Tolerance	Max.	±	Min.	size	Tolerance	H13		Min			
78	2.5	± 0.06	82.5	+1.3 -0.54	8.5	6.8	3	81	+0.35 0 (H12)	2.85	1.5	4.5			
80	2.5		85.5		8.5	7	3	83.5		2.65	1.75	5.3			
82	2.5		87.5		8.5	7	3	85.3		2.65	1.75	5.3			
85	3	± 0.07	90.5		8.6	7.2	3.5	88.5		3.15	1.75	5.3			
88	3		93.5		8.6	7.4	3.5	91.5		3.15	1.75	5.3			
90	3		95.5		8.6	7.6	3.5	93.5		3.15	1.75	5.3			
92	3		97.5		8.7	7.8	3.5	95.5		3.15	1.75	5.3			
95	3		100.5		8.8	8.1	3.5	98.5		3.15	1.75	5.3			
98	3		103.5		9	8.3	3.5	101.5		3.15	1.75	5.3			
100	3		105.5		9.2	8.4	3.5	103.5		3.15	1.75	5.3			
102	4		± 0.08	108	9.5	8.5	3.5	106	+0.54 0 (H13)	4.15	2	6			
105	4			112	9.5	8.7	3.5	109		4.15	2	6			
108	4			115	9.5	8.9	3.5	112		4.15	2	6			
110	4	117		10.4	9	3.5	114	4.15		2	6				
112	4	119		10.5	9.1	3.5	116	4.15		2	6				
115	4	± 0.08		122	+1.5 -0.63	11	9.3	3.5	119	+0.63 0 (H13)	4.15	2	6		
120	4			127		11	9.7	3.5	124		4.15	2	6		
125	4			132		11	10	4	129		4.15	2	6		
130	4			137		11.2	10.2	4	134		4.15	2	6		
135	4			142		11.2	10.5	4	139		4.15	2	6		
140	4		147	11.4		10.7	4	144	4.15		2	6			
145	4		152	12		10.9	4	149	4.15		2	6			
150	4		158	12		11.2	4	155	4.15		2	7.5			
155	4		164	13		11.4	4	160	4.15		2.5	7.5			
160	4		169	13		11.6	4	165	4.15		2.5	7.5			
165	4	± 0.09	174.5	+1.70 -0.72	13.5	11.8	4	170	+0.72 0 (H13)	4.15	2.5	7.5			
170	4		179.5		13.5	12.2	4	175		4.15	2.5	7.5			
175	4		184.5		14.2	12.7	4	180		4.15	2.5	7.5			
180	4		189.5		14.2	13.2	4	185		4.15	2.5	7.5			
185	4		194.5		14.2	13.7	4	190		4.15	2.5	7.5			
190	4		199.5		14.2	13.8	4	195		4.15	2.5	7.5			
195	4		204.5		14.2	13.8	4	200		4.15	2.5	7.5			
200	4		209.5		14.2	14	4	205		4.15	2.5	7.5			
210	5		± 0.09		222	+2.0 -0.81	14.2	14		4	216	+0.81 0 (H13)	5.15	3	9
220	5				232		14.2	14		4	226		5.15	3	9
230	5	242		14.2	14		4	236	5.15	3	9				
240	5	252		14.2	14		4	246	5.15	3	9				
250	5	262		14.2	14		4	256	5.15	3	9				
260	5	275		16.2	16	5	268	5.15	4	12					
270	5	285		16.2	16	5	278	5.15	4	12					
280	5	295		16.2	16	5	288	5.15	4	12					
290	5	305		16.2	16	5	298	5.15	4	12					
300	5	315		16.2	16	5	308	5.15	4	12					

# Standard Internal Circlip Heavy Type: IS 3075



shall Dia, d1 Nom. Size	Circlips							Groove						
	s		d3		a	b <sup>d</sup>	d <sub>5</sub>	d2t		mt	t	n		
	Size	Tolerance	Size	Tolerance	Max.	μ	Min.	size	Tolerance	H13		Min		
20	1.5	± 0.05	21.5	+0.42 -0.21	4.5	2.4	2	21	+0.13 0 (H11)	1.6	0.5	1.5		
22	1.5		23.5		4.7	4.8	2	23		1.6	0.5	1.5		
24	1.5		25.9		4.9	3	2	25.2		1.6	0.6	1.8		
25	1.5		26.9		5	3.1	2	26.2	+0.21 0 (H12)	1.6	0.6	1.8		
26	1.5		27.9	5.1	3.1	2	27.2	1.6		0.6	1.8			
28	1.5		30.1	+0.50 -0.25	5.3	3.2	2	29.4	+0.25 0 (H12)	1.6	0.7	2.1		
30	1.5		32.1		5.5	3.3	2	31.4		1.6	0.7	2.1		
32	1.5		34.4		5.7	3.4	2	33.7		1.6	0.85	2.6		
34	1.75		36.5		5.9	3.7	2.5	35.7		1.85	0.85	2.6		
35	1.75		37.8		6	3.8	2.5	37		1.85	1	3		
37	1.75		39.8		6.2	3.9	2.5	39		1.85	1	3		
38	1.75		40.8	6.3	3.9	2.5	40	1.85		1	3			
40	2		± 0.06	43.5	+0.90 -0.39	6.5	3.9	2.5		42.5	+0.30 0 (H12)	2.15	1.25	3.8
42	2			45.5		6.7	4.1	2.5		44.5		2.15	1.25	3.8
45	2	48.5		7		4.3	2.5	47.5		2.15		1.25	3.8	
47	2	50.5		+1.10 -0.46	7.2	4.4	2.5	49.5	2.15	1.25		3.8		
50	2.5	54.2			7.5	4.6	2.5	53	2.65	1.5		4.5		
52	2.5	56.2			7.7	4.7	2.5	55	2.65	1.5		4.5		
55	2.5	59.2	+1.30 -0.54	8	5	2.5	58	+0.35 0 (H12)	2.65	1.5	4.5			
60	3	64.2		8.5	5.4	2.5	63		3.15	1.5	4.5			
62	3	66.2		8.6	5.5	2.5	65		3.15	1.5	4.5			
65	3	69.2		8.7	5.8	3	68		3.15	1.5	4.5			
68	3	72.5		8.8	6.1	3	71		3.15	1.5	4.5			
70	3	74.5		9	6.2	3	73		3.15	1.5	4.5			
72	3	76.5		9.2	6.4	3	75		3.15	1.5	4.5			
75	3	79.5		9.3	6.6	3	78		3.15	1.5	4.5			
80	4	± 0.08	85.5	+1.30 -0.54	9.5	7	3	83.5	+0.35 0 (H12)	4.15	1.75	5.3		
85	4		90.5		9.7	7.2	3.5	83.5		4.15	1.75	5.3		
90	4		95.5		10	7.8	3.5	93.5		4.15	1.75	5.3		
95	4		100.5		10.3	8.1	3.5	98.5		4.15	1.75	5.3		
100	4		105.5		10.5	8.4	3.5	103.5		4.15	1.75	5.3		

# Inverted Internal Circlip – J Type – DIN 5008, M1308

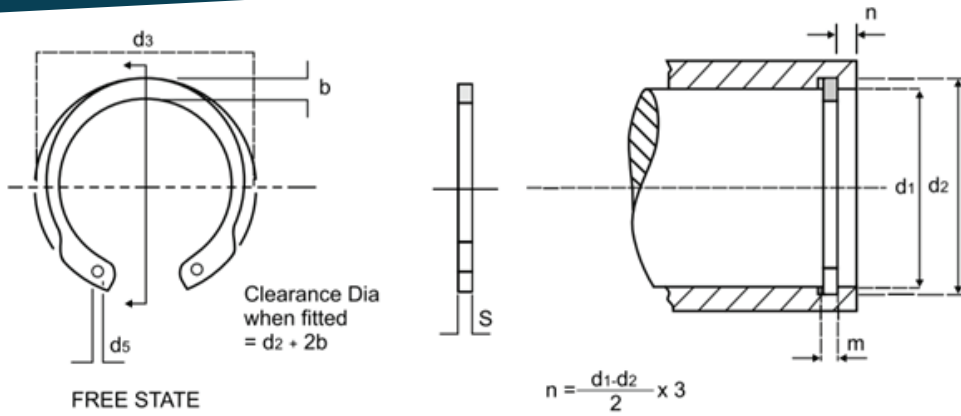

Material: Type: Carbon Spring Steel  
 Hardness: d1 - 12 to 47 : 47 to 54 HRC  
 d1 - 48 to 100 : 44 to 51 HRC

Finish: Phosphating or as per requirements

Circlip Dimensions							Groove Dimensions				
Nominal Diameter (d1)	Thickness (s)	Tolerance	Unstressed Diameter d3	Tolerance	Beam (b)	Lug Hole (d5) min	Weight kg/1000	Groove Diameter (d2)	Tolerance	Groove Width (m)	Radial depth of Groove (t)
12	0.60	-0.05	13.1	+0.42-0.13	1.8	1.0	0.25	12.6	+0.11	0.70	0.30
15	0.80		16.1		2.0	1.0	0.41	15.7		0.90	0.35
16	1.00		17.3		2.1	1.3	0.53	16.8		1.10	0.40
17	1.00		18.3		2.1	1.3	0.58	17.8		1.10	0.40
18	1.00		19.5		2.2	1.3	0.62	19.0		1.10	0.50
19	1.00		20.5		2.2	1.3	0.66	20.0		1.10	0.50
20	1.00		21.5		2.3	1.3	0.80	21.0		1.10	0.50
21	1.00		22.5		2.4	1.3	0.81	22.0		1.10	0.50
22	1.00		23.5		2.4	1.3	0.83	23.0		1.10	0.50
24	1.20		25.9		2.8	1.5	1.30	25.2		1.30	0.50
25	1.20	26.9	2.8	1.5	1.40	26.2	1.30	0.60			
26	1.20	27.9	3.0	1.5	1.50	27.2	1.30	0.60			
27	1.20	29.1	3.0	1.5	1.53	28.4	1.30	0.60			
28	1.20	-0.06	30.1	+0.50-0.25	3.1	1.5	1.80	29.4	+0.25	1.30	0.70
30	1.20		32.1		3.2	1.5	2.03	30.4		1.30	0.70
32	1.20		34.4		3.3	1.5	2.05	33.7		1.30	0.85
33	1.20		35.5		3.3	1.5	2.35	34.7		1.30	1.00
35	1.50		37.8		3.4	1.7	3.20	37.0		1.60	1.00
36	1.50		38.8		3.6	1.7	3.23	38.0		1.60	1.00
38	1.50		40.8		3.8	1.7	3.68	40.0		1.60	1.00
40	1.75		43.5		4.2	2.0	4.75	42.5		1.85	1.25
42	1.75		45.5		4.2	2.0	5.20	44.5		1.85	1.25
45	1.75		48.5		4.2	2.0	6.00	47.5		1.85	1.25
47	1.75	50.5	4.7	2.0	6.50	49.5	1.85	1.25			
48	1.75	51.5	4.7	2.0	7.00	50.5	1.85	1.25			
50	2.00	-0.07	54.2	+1.10-0.46	5.2	2.5	8.50	53.0	+0.30	2.15	1.50
52	2.00		56.2		5.2	2.5	9.00	55.0		2.15	1.50
55	2.00		59.2		5.2	2.5	10.00	58.0		2.15	1.50
57	2.00		61.2		5.2	2.5	10.25	60.0		2.15	1.50
58	2.00		62.2		5.2	2.5	10.50	61.0		2.15	1.50
60	2.00		64.2		5.2	2.5	11.25	63.0		2.15	1.50
62	2.00		66.2		5.2	2.5	11.75	65.0		2.15	1.50
65	2.50		69.2		5.7	2.5	16.25	68.0		2.65	1.50
67	2.50		71.5		5.7	2.5	17.30	70.0		2.65	1.50
68	2.50		72.5		5.7	2.5	17.75	71.0		2.65	1.50
72	2.50	76.5	6.0	2.58	19.60	75.0	2.65	1.50			
80	2.50	85.5	6.0	2.5	22.90	83.5	2.65	1.75			
85	3.00	-0.08	90.5	+1.30-0.54	6.6	3.0	30.00	88.5	+0.35	3.15	1.75
90	3.00		95.5		6.6	3.0	33.00	93.5		3.15	1.75
95	3.00		100.5		7.4	3.0	37.50	98.5		3.15	1.75
100	3.00		105.5		7.4	3.0	41.90	103.5		3.15	1.75

# K Type Internal Circlip – DIN 984

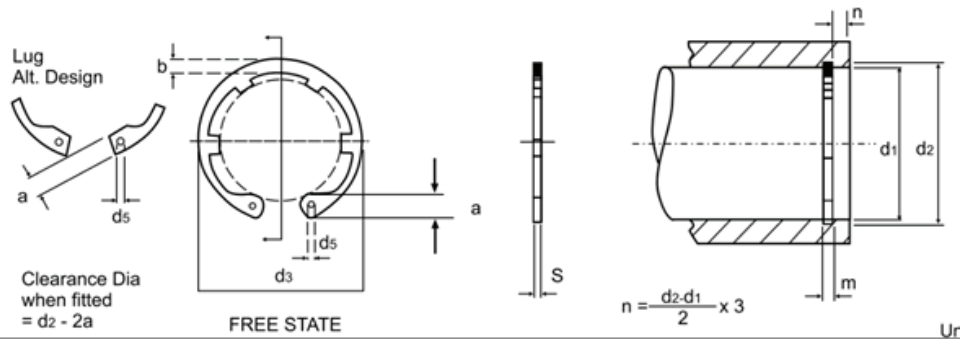

Nominal Bore Size d1	CIRCLIP DIMENSION							GROOVE DIMENSION			
	Free Diameter d3	Free Diameter Tolerance	Thickness S mm	Tolerance	Lug a (Max.)	Large Section B	HoleDia d5 (Min)	Diameter d2	Tolerance	Width m (Min.)	
16	17.30	+0.42 -0.13	1.00	-0.06	3.4	2.1	1.70	16.80	+0.110	1.10	
17	18.30				17.80	1.10					
18	19.50				+0.150	1.00	4.1	2.3	2.00	19.00	1.10
19	20.50						20.00	1.10			
20	21.50						21.00	1.10			
21	22.50						22.00	1.10			
22	23.50						23.00	1.10			
23	24.60	24.10	1.30								
24	25.90	+0.210	1.20				4.2	2.6	2.00	25.20	1.30
25	26.50				26.20	1.30					
26	28.50				27.20	1.30					
27	29.10				28.40	1.30					
28	30.10				29.40	1.30					
30	32.10				31.40	1.30					
31	33.40				+0.250	1.50	4.9	3.0	2.00	32.70	1.30
32	34.40	33.70	1.30								
34	36.50	35.70	1.60								
35	37.80	37.00	1.60								
36	38.80	38.00	1.60								
38	40.80	40.00	1.60								
40	43.50	42.50	1.85								
42	45.50	+0.90 -0.39	1.75	7.2	4.0	2.50	46.50	1.85			
44	47.50			47.50	1.85						
45	48.50			49.50	1.85						
47	50.50			50.50	1.85						
48	51.50			53.00	1.85						
50	54.20			+0.300	2.00	7.2	4.5	2.50	55.00	2.15	
52	56.20					58.00	2.15				
55	59.20	60.00	2.15								
57	61.20	61.00	2.15								
58	62.20	63.00	2.15								
60	64.20	65.00	2.15								
62	66.20	65.00	2.15								
65	69.20	+0.350	2.00			10.2	5.8	3.00	68.00	2.65	
67	71.50					70.00	2.65				
68	72.50					71.00	2.65				
70	74.50					73.00	2.65				
72	76.50					75.00	2.65				
75	79.50					78.00	2.65				
80	85.50					+0.540	2.50	10.2	7.0	3.00	83.00
85	90.50	-0.08	3.00	12.2	7.4			3.50	88.50	3.15	
90	95.50			93.50	3.15						
95	100.50			98.50	3.15						
100	105.50	-0.08	3.00	12.2	8.1			3.50	103.50	3.15	
110	117.00			114.00	4.15						
115	122.00			119.00	4.15						

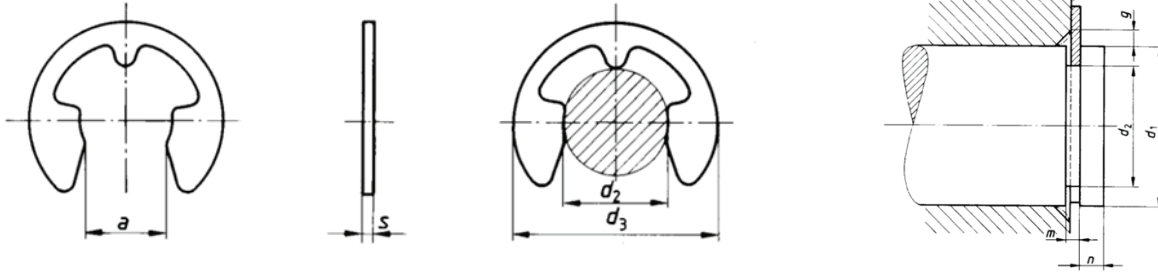

Material: Carbon Spring Steel

Finish: Phosphating or as per requirements

Hardness: 46 – 54 HRC

Groove Dia, d1 Nominal Size	Shaft Dia Range, d1		Circlip				Groove				
			s		a		d2		m*		n min
	From	To	Size	Tolerance	Size	Tolerance	Size	Tolerance	Size	Tolerance	
0.8	1	1.4	0.2	±0.02	0.58	±0.04	0.8	0 -0.06	0.24	+0.04 0	0.4
1.2	1.4	2	0.3		1.01		1.2		0.34		0.6
1.5	2	2.5	0.4		1.28		1.5		0.44		0.8
1.9	2.5	3	0.5	±0.03	1.61	±0.048	1.9	0 -0.075	0.54	+0.05 0	1
2.3	3	4	0.6		1.94		2.3		0.64		1
3.2	4	5	0.7		2.70		3.2		0.64		1
4	5	7	0.7		3.34		4		0.74		1.2
5	6	8	0.7		4.11		5		0.74		1.2
6	7	9	0.7	5.26	6	0.74	1.2				
7	8	11	0.9	5.84	7	0	0.94	1.5			
8	9	12	1	6.52	±0.058	8	0 -0.09	1.05	+0.08 0	1.8	
9	10	14	1.1	7.63		9		1.15		2	
10	11	15	1.2	8.32		10		1.25		2	
12	13	18	1.3	10.45	±0.07	12	0 -0.11	1.35	+0.08 0	2.5	
15	16	24	1.5	12.61		15		1.55		3	
19	20	31	1.75	15.92	±0.084	19	0 -0.13	1.80	+0.08 0	3.5	
24	25	38	2	21.88		24		2.05		4	
30	32	42	2.5	25.88		30		2.55		4.5	

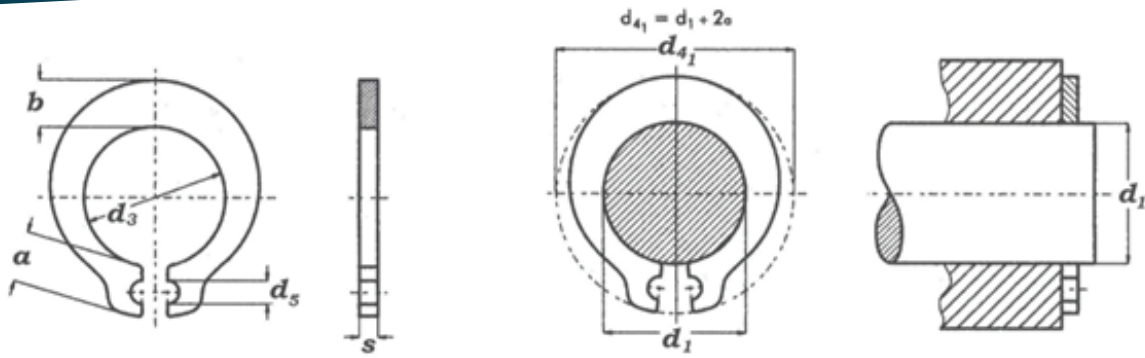

Material: Carbon Spring Steel

Finish: Phosphating or as per requirements

Nominal Diameter (d1)	Thickness (s)	Unstressed Diameter (d3)	Tolerance	Lug (a) max	Beam (b)	Lug Hole (d5) Min	Diameter During Assembly Over Nominal Diameter (d41)
1.5	0.40	1.40	±0.020	1.7	0.7	0.9	5.1
2.0	0.60	1.90		1.9	1.0	0.9	6.0
2.2	0.60	2.05	±0.025	1.9	1.1	0.9	6.2
2.8	0.60	2.35	±0.030	1.9	1.2	0.9	6.5
3.0	0.60	2.65	±0.035	2.0	1.3	0.9	7.0
3.5	0.60	2.85	±0.040	2.1	1.4	0.9	7.4
4.0	0.60	3.30	±0.050	2.3	1.6	0.9	8.3
4.5	0.80	3.80	±0.060	2.7	1.8	1.2	9.6
5.0	0.80	4.25		2.9	2.0	1.3	10.5
5.5	0.80	4.75	±0.075	2.9	2.2	1.3	11.0
6.0	0.80	5.20		3.0	2.2	1.3	11.7
7.0	1.00	5.70		3.2	2.4	1.4	12.6
8.0	1.00	6.70	±0.090	3.4	2.7	1.4	14.0
9.0	1.00	7.70		3.5	3.0	1.4	15.2
10.0	1.20	8.65		4.7	3.5	2.0	18.6
10.5	1.20	9.65		4.7	3.8	2.0	19.6
11.0	1.20	10.20	±0.110	4.8	4.2	1.5	18.7
12.0	1.20	10.60		4.8	4.6	2.0	20.8
13.0	1.20	11.60		5.3	5.0	2.0	21.8
13.8	1.20	12.55		5.1	5.4	2.2	23.8
14.0	1.50	13.50		5.1	5.4	2.2	24.8
15.0	1.50	14.50		5.1	5.6	2.2	25.0
16.0	1.50	15.40		5.6	5.8	2.5	26.4

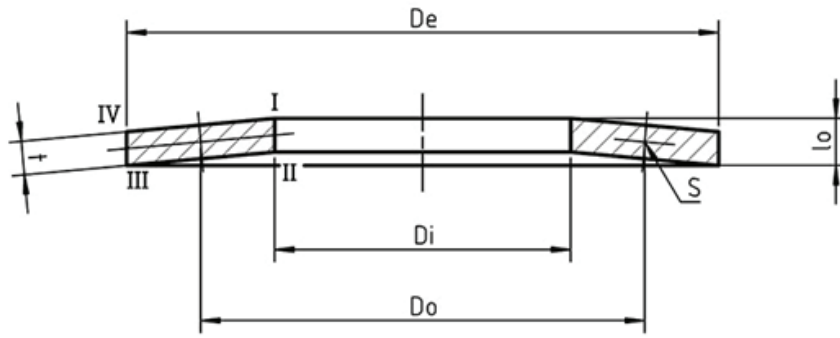

Material: Carbon Spring Steel  
 Hardness: 42 to 52HRC

Finish: Phosphating

Heavy Pattern

Group	De(h1)	D1(h1)	t or (t')	Tolerance	hb	lo	Tolerance	
1	8	4.2	0.4	+0.02-0.06	0.2	0.6	+0.02	
	10	5.2	0.5		0.25	0.75		
	12.5	6.2	0.7	+0.03-0.09	0.3	1	+0.03	
	14	7.2	0.8		0.3	1.1		
	16	8.2	0.9		0.35	1.25		
	18	9.2	1		0.4	1.4		
2	20	10.2	1.1	+0.04-0.12	0.45	1.55	+0.04	
	22.5	11.2	1.25		0.5	1.75		
	25	12.2	1.5		0.55	2.05		
	28	14.2	1.5		0.65	2.15		
	31.5	16.3	1.75		0.7	2.45		
	35.5	18.3	2		0.8	2.8		
	40	20.43	2.25		0.9	3.15		
	45	22.4	2.5	1	3.5			
	50	25.4	3	+0.05-0.15	1.1	4.1	+0.05	
	56	28.5	3		1.3	4.3		
	63	31	3.5		1.4	4.9		
	3	71	36	4	+0.05-0.15	1.6	5.6	+0.10
		80	41	5		1.7	6.7	
		90	46	5	±0.10	2	7	
100		51	6	2.2		8.2		
112		57	6	2.5		8.5		
125		64	8(7.5)	2.6		10.6		
140		72	8(7.5)	3.2		11.2		
160		82	10(9.4)	3.5		13.5		
180	92	10(9.4)	4	14				
200	102	12(11.25)	4.2	16.2				
225	112	12(11.25)	5	17				
250	127	14(13.1)	5.6	19.6				



Light Pattern

Group	De(h1)	D1(H12)	t or (t <sup>-</sup> )	Tolerance	h <sub>o</sub>	l <sub>o</sub>	Tolerance		
1	8	4.2	0.3	+0.10-0.05	0.25	0.55	+0.10		
	10	5.2	0.4		0.3	0.7			
	12.5	6.2	0.5		0.35	0.85			
	14	7.2	0.5		0.4	0.9			
	16	8.2	0.6		0.45	1.05			
	18	9.2	0.7		0.5	1.2			
2	20	10.2	0.8		+0.15	0.55	1.35	+0.15	
	22.5	11.2	0.8			0.65	1.45		
	25	12.2	0.9			0.7	1.6		
	28	14.2	1			0.8	1.8		
	2	31.5	16.3		1.25	+0.15-0.08	0.9	2.15	+0.20
		35.5	18.3		1.25		1	2.25	
		40	20.4	1.5	1.15		2.65		
		45	22.4	1.75	1.		3.05		
		50	25.4	2	1.4		3.4		
		56	28.5	2	1.6		3.6		
		2	63	31	2.5	+0.20-0.10	1.75	4.25	+0.25
			71	36	2.5		2.3	4.5	
			80	41	3		2.5	5.3	
			90	46	3.5	+0.30-0.15	2.8	6	
100	51		3.5	3.2	6.3				
112	57		4	3.5	7.2				
3	125	64	5	+0.30	4	8.5	+0.30		
	140	72	5		4.5	10.5			
	160	82	6		5.1	11.1			
	180	92	6						
	200	102	8(7.5)		±0.30	5.6		13.6	
	225	112	8(7.5)	6.5		14.5			
	250	127	10(94)	7		17			



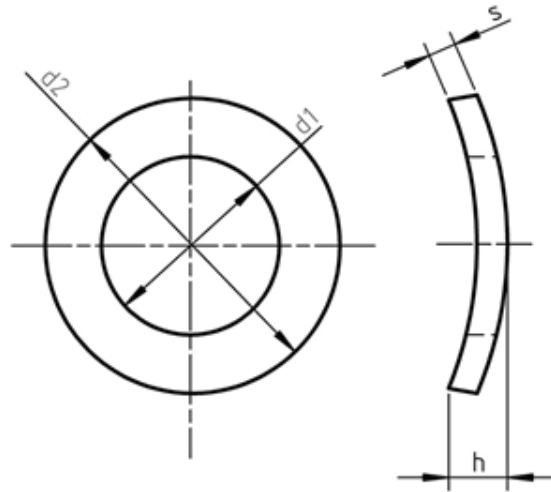

Material: Carbon Spring Steel  
 Hardness: 42 to 50 HRC

Finish: Phosphating or as per requirements

**Type A**

Nominal size	s		d1	d2	h		for size
	Nominal size	tol			min.	max.	
3	0.5	+0.05	3.2	8	0.8	1.6	M3
3.5	0.5		3.7	8	0.9	1.8	M3.5
4	0.5		4.3	9	1	2	M4
5	0.5		5.3	11	1.1	2.2	M5
6	0.5	+0.06	6.4	12	1.3	2.6	M6
7	0.8		7.4	14	1.5	3	M7
8	0.8	+0.07	8.4	15	1.5	3	M8
10	1		10.5	21	2.1	4.2	M10
12	1.2	+0.08	13	24	2.5	5	M12
14	1.6		15	28	3	6	M14
16	1.6		17	30	3.2	6.4	M16
18	1.6		19	34	3.3	6.6	M18
20	1.6	+0.1	21	36	3.7	7.4	M20
22	1.8		23	40	3.9	7.8	M22
24	1.8		25	44	4.1	8.2	M24
27	2		28	50	4.7	9.4	M27
30	2.2		31	56	5	10	M30
33	2.2	34	60	5.3	10.6	M33	

**Type B**

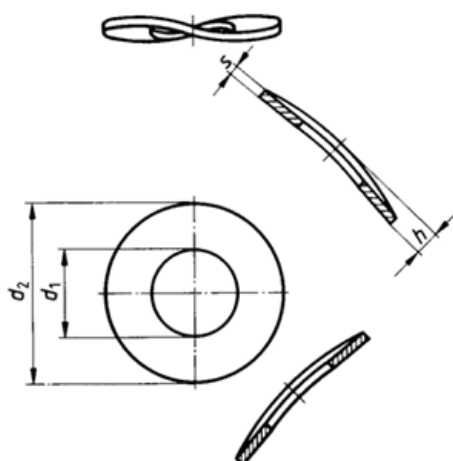

Nom. Size	s		d1 H14	d2js16	h		for Size
	Nom. Size	Tolerance			min.	max.	
3	0.5	+0.05	3.2	8	0.8	1.6	M3
3.5	0.5		3.7	8	0.9	1.8	M3.5
4	0.5		4.3	9	1	2	M4
5	0.5		5.3	11	1.1	2.2	M5
6	0.5		6.4	12	1.3	2.6	M6
7	0.8	+0.06	7.4	14	1.5	3	M7
8	0.8		8.4	15	1.5	3	M8
10	1	+0.07	10.5	21	2.1	4.2	M10
12	1.2		13	24	2.5	5	M12
14	1.6	+0.08	15	28	3	6	M14
16	1.6		17	30	3.2	6.4	M16
18	1.6		19	34	3.3	6.6	M18
20	1.6		21	36	3.7	7.4	M20
22	1.8	+0.01	23	40	3.9	7.8	M22
24	2		25	44	4.1	8.2	M24
27	2		28	50	4.7	9.4	M27
30	2.2		31	56	5	10	M30
33	2		34	60	5.3	10.6	M33
36	2.5		37	68	5.8	11.6	M36

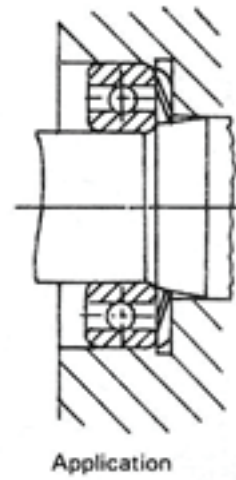
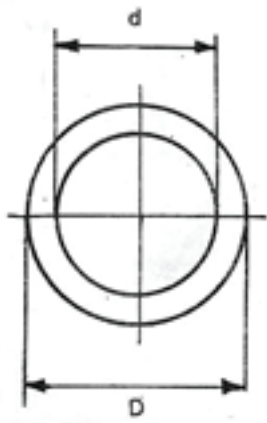

Material: Carbon Spring Steel  
Hardness: 40 – 50HRC

Finish: Phosphating

BEARINGS NUMBER			O.D.	I.D.	Thickness mm	Hieght Appr. mm
6309	6013	6211	99 mm	89 mm	0.5	4.0
6308	6011	6210	89 mm	79 mm	0.5	4.5
6307	0010	6208	79 mm	71 mm	0.5	4.2
6306		6207	71 mm	61 mm	0.5	3.5
6305	6007	6206	61 mm	51 mm	0.5	5.0
6304		6205	51 mm	41 mm	0.5	4.5
6302	6004		41 mm	34 mm	0.4	4.2
6300	6003	6202	34 mm	28 mm	0.4	4.3
6303	6005	6204	46.5 mm	39.5 mm	0.4	5.2
		6203	39.5 mm	34 mm	0.4	5.5
	6002	6201	31.5 mm	25.5 mm	0.3	2.5
	6000		25.5 mm	21mm	0.3	2.5



Type A

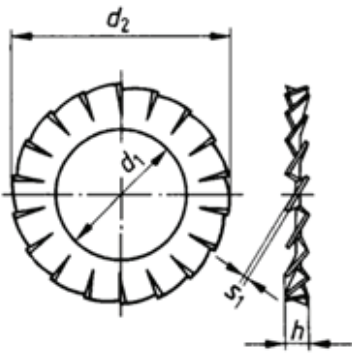

Type B

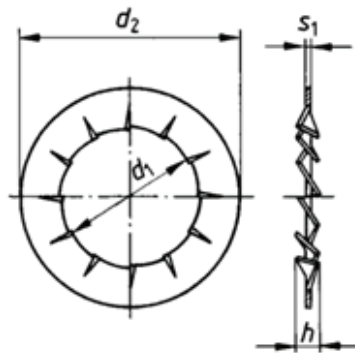

$$h \approx 3s_1$$

Type C

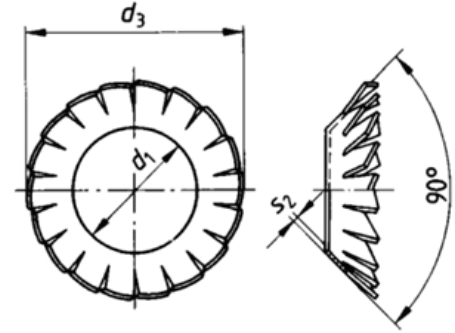

Material: Carbon Spring Steel  
Hardness: 44 to 52 HRC

Finish: Phosphating or as per requirements

Nominal Size	s2 *	d1 H13	d3 h14	Number of Teeth, Min		For SCrew Thread Size
				Type A	Type B	
1.6	0.3	1.8	3.6	9	7	1.6
2	0.3	2.4	4.5	9	7	2
2.5	0.4	2.9	5.5	9	7	2.5
3	0.4	3.4	6	9	7	3
3.5	0.5	3.9	7	10	8	3.5
4	0.5	4.5	8	11	8	4
5	0.6	5.5	10	11	8	5
6	0.7	6.6	11	12	9	6
7	0.8	7.7	12.5	14	10	7
8	0.8	9	15	14	10	8
10	0.9	11	18	6	12	10
12	1	13.5	20.5	16	12	12
14	1	15.5	24	18	14	14
16	1.2	17.5	26	18	14	16
18	1.4	20	30	18	14	18
20	1.4	22	33	20	16	20
22	1.5	24	36	20	16	22
24	1.5	27	38	20	16	24
27	1.6	30	44	22	18	27
30	1.6	33	48	22	18	30

Type C

Nominal Size	s2 *	d1 H13	d3 h14	Number of Teeth, Min	For SCrew Thread Size
2	0.2	2.2	4.2	10	2
2.5	0.2	2.7	5.1	10	2.5
3	0.2	3.2	6	12	3
3.5	0.25	3.7	7	12	3.5
4	0.25	4.3	8	14	4
5	0.3	5.3	9.8	14	2
6	0.4	6.4	11.8	16	6
8	0.4	8.4	15.3	18	8
10	0.5	10.5	19	20	10
12	0.5	13	23	26	12
14	0.6	15	26.2	28	14
16	0.6	17	30.2	30	16

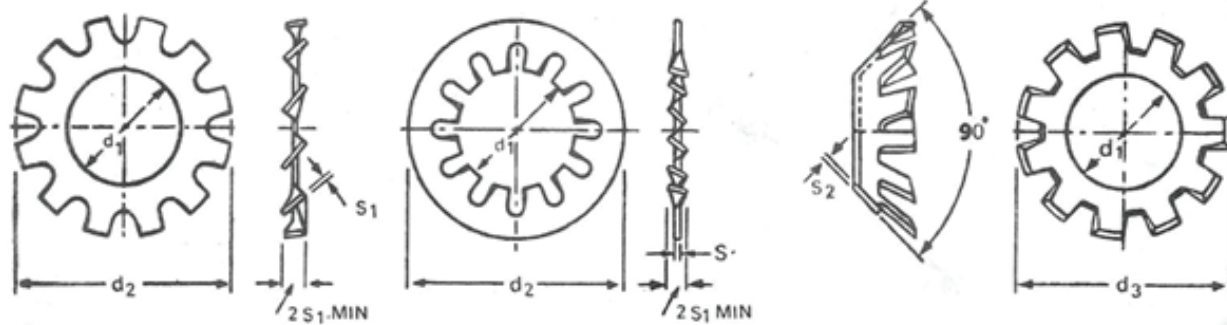

Type A: Externally Toothed T

Type B: Internally Toothed

Type C: Countersunk

Material: Carbon Spring Steel

Finish: Phosphating or as per requirements

Hardness: 42 to 49 HRC

Nominal Size d1 H13	d2(h14)	d3	s1	s2	Number of Teeth Min Types		Suitable Screw Size
					A and B	C	
					1.7	3.6	
(1.9)	4	-	0.3	-	6	-	M1.8
2.2	4.5	4.2	0.3	0.2	6	6	M2
2.7	5.5	5.1	0.4	0.2	6	6	M2.6
3.2	6	6	0.4	0.2	6	6	M3
(3.7)	7	7	0.5	0.25	6	6	M3.5
4.3	8	8	0.5	0.25	8	8	M4
5.1	9	-	0.5	-	8	-	M5
5.3	10	9.8	0.6	0.3	8	8	M5
6.4	11	11.8	0.7	0.34	8	10	M6
(7.4)	12.5	-	0.8	-	8	-	M7
8.2	14	-	0.8	-	8	-	M8
8.4	15	15.3	0.8	0.4	8	10	M8
10.5	18	19	0.9	0.5	9	10	M10
12.5	20.5	23	1	0.5	10	10	M12
(14.5)	24	26.2	1	0.6	10	12	M14
16.5	26	30.2	1.2	0.6	12	12	M15
(19)	30	-	1.4	-	12	-	M18
21	33	-	1.4	-	12	-	M20
(23)	36	-	1.5	-	14	-	M22
25	38	-	1.5	-	14	-	M24
(28)	44	-	1.6	-	14	-	M27
31	48	-	1.6	-	14	-	M30

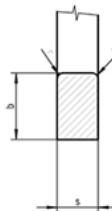
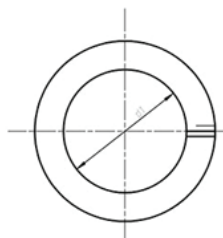
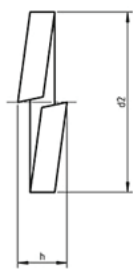

Form A: Washer with Bent Ends

Form B: Washer with Flat Ends

Material: Carbon Spring Steel

Finish: As per requirement

Hardness: 44 to 52 HRC

Nominal Size	d1		d2 Max	b		s		r	k	h2		For Bolt Nut or Screw Size
	Basic	Tol		Basic	Tol	Basic	Tol			Min	Max	
2	2.1	+0.3	4.4	0.9	+0.1	0.5	+0.1	0.1	-	1	1.2	M2
2.2	2.3		4.9	1		0.6		0.1	-	1.2	1.4	M2.2
2.3	2.6		5.1	1		0.6		0.1	-	1.2	1.4	M2.5
3	3.1		6.2	1.3		0.8		0.2	-	1.6	1.9	M3
3.5	3.6		6.7	1.3		0.8		0.2	0.15	1.6	1.9	M3.5
4	4.1		7.6	1.5		0.9		0.2	0.15	1.6	2.1	M4
5	5.1	+0.4	10.2	1.8	+0.15	1.2	+0.15	0.2	0.15	2.4	2.8	M5
6	6.1		11.8	2.5		1.6		0.3	0.2	3.2	3.8	M6
7	7.1		12.8	2.5		1.6		0.3	0.2	3.2	3.8	M7
8	8.2	+0.6	14.8	3	+0.2	2	+0.2	0.5	0.3	4	4.7	M8
10	10.2		18.1	3.5		2.2		0.5	0.3	4.4	5.2	M10
12	12.2		21.1	4		2.5		1.0	0.4	5	5.9	M12
14	14.2		24.1	4.5		3		1.0	0.4	6	7.1	M14
16	16.2	+0.8	27.4	5	+0.2	3.5	+0.2	1.0	0.4	7	8.3	M16
18	18.2		29.4	5		3.5		1.0	0.4	7	8.3	M18
20	20.2	+1.0	33.6	6	+0.2	4	+0.2	1.0	0.4	8	9.4	M22
22	22.5		35.9	6		4		1.0	0.4	8	9.4	M24
24	24.5		40	7		5		1.6	0.5	10	11.8	M27
27	27.5	+1.2	43	7	+0.25	5	+0.25	1.6	0.5	10	11.8	M30
30	30.5		48.2	8		6		1.6	0.8	12	14.2	M33
33	33.5		53.2	10		6		1.6	0.8	12	14.2	M36
38	36.5		58.2	10		6		1.6	0.8	12	14.2	M39
39	42.5		61.2	10		6		1.6	0.8	12	14.2	M42
42	45.5		71.2	12		7		2	0.8	14	16.5	M45
45	49	+1.5	75	12	+0.25	7	+0.25	2	0.8	14	16.5	M48
48	53		83	12		7		2	0.8	14	16.5	M52
52	57		87	14		8		2	1	16	18.9	M58
56	61		91	14		8		2	1	16	18.9	M60
64	65		95	14		8		2	1	16	18.9	M64
72	73		103	14		8		2	1	16	18.9	M72
76	77		109	14		8		2	1	16	18.9	M78
80	81		111	14		8		2	1	16	18.9	M80
90	91		121	14		8		2	1	16	18.9	M90
100	101		131	14		8		2	1	16	18.9	M98

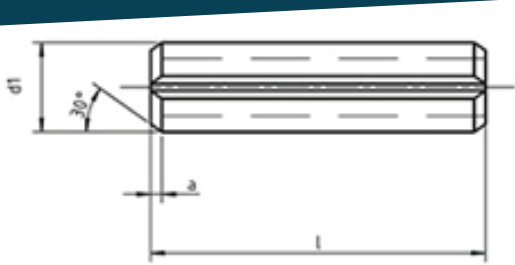

Up to 4.5mm Nominal Diameter

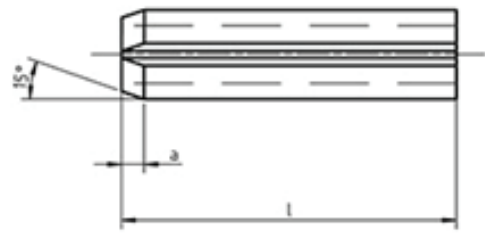
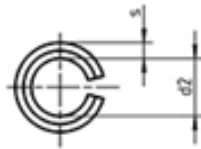

Nominal Diameter 5mm and above

Material: Carbon Spring Steel  
Hardness: 45 – 50 HRC

Finish: Phosphating

## Light Pattern

Nominal Diameter mm	s	a	d1	Tolerance on d1	d1 ≈	For Bolt Size	Corresponding Washer	Preferred on Length
2	0.2	0.35	2.3	+0.1	1.9	-	-	4-30
2.5	0.25	0.45	2.8		2.3	-	-	4-30
3	0.3	0.5	3.3	+0.2	2.7	-	-	4-40
3.5	0.35	0.6	3.3		3.1	-	-	4-40
4	0.5	0.7	4.4		3.4	-	-	4-50
4.5	0.5	0.8	4.8		3.8	M3	3.2	4-50
5	0.5	1.6	5.4		4.4	-	-	5-50
6	0.75	1.6	6.4	+0.3	4.9	M4	4.3	10-100
7	0.75	1.6	7.5		6.0	M5	5.3	10-100
8	0.75	2	8.5		7.0	M6	6.4	10-120
10	1	2	10.5	+0.4	8.5	-	-	10-150
11	1	2	11.5		9.5	M8	8.4	10-150
12	1	2	12.5		10.5	-	-	10-180
13	1.25	2	13.5		11.0	M10	10.5	10-180
14	1.5	2	14.5		11.5	-	13	10-200
16	1.5	2	16.5		13.5	M12	15	10-200
18	1.75	2	18.5		16.5	-	-	10-200
20	2	2	20.5		16.5	M13	17	14-200
21	2	3	21.5		19.5	M18	19	14-200
23	2	3	23.5		21.5	M20	21	14-200
25	2.5	3	25.5		23.5	M22	23	14-200
30	2.5	3	28.5		25.5	M24	25	14-200
35	3.5	3	30.5		28.5	M27	28	20-200
40	4	4	35.5		32.5	M30	31	20-200
45	4	4	40.5		37.5	M36	37	20-200
50	5	4	50.5	40.5	M30	40	20-200	



**Heavy Pattern**

Nominal Diameter	S	a	d1	Tolerance on d1	d1 ≈	For Bolt Size	Corresponding Washer	Preferred on Length
1	0.2	0.15	1.2	+0.1	0.8	-	-	4-30
1.5	0.3	0.25	1.7		1.1	-	-	4-30
2	0.4	0.35	2.3		1.5	-	-	4-40
2.5	0.5	0.45	2.8		1.8	-	-	4-40
3	0.6	0.	3.3	+0.2	2.1	-	-	4-50
3.5	0.7	5	4.8		2.3	-	3.2	4-50
4	0.8	0.6	4.4		2.8	-	-	5-50
4.5	1	0.7	4.9		2.9	-	4.3	10-100
5	1	0.8	5.4	+0.3	3.4	-	5.3	10-100
6	1.2	1.6	6.4		3.9	-	6.4	10-120
8	1.5	1.6	8.5		5.5	M3	-	10-150
10	2	2	10.5		6.5	M4	8.4	10-150
12	2.5	2	12.5		7.5	M5	-	10-180
13	3	2	13.5		8.5	M6	10.5	10-180
14	3	2	14.5		10.5	-	13	10-200
16	3.5	2	16.5		11.5	-	15	10-200
20	4	2	18.5		12.5	M8	-	10-200
21	4	3	20.5		13.5	M10	17	14-200
25	5	3	21.5	15.5	-	19	14-200	
28	5.5	3	25.5	17.5	M12	21	14-200	
30	6	3	28.8	18.5	M14	23	14-200	
32	6	3	30.5	20.5	M16	25	14-200	
35	7	3	32.5	21.5	M20	28	20-200	
38	7.5	4	38.5	23.5	M22	31	20-200	
40	7.5	4	40.5	25.5	M24	37	20-200	
45	8.5	4	45.5	28.5	M27	40	20-200	
50	9.5	4	50.5	31.5	M30			

PREFERRED ON LENGHTS	
Length mm	In Steps of mm
4 to 6	1
6 to 32	2
32 to 40	4
40 to 100	5
100 to 200	20

TOLERANCES ON LENGHTS	
Length mm	Tolerance mm
4 to 10	+0.5
12 to 50	+1.0
50 to 200	+1.5





Cathect Engineering Co.



# CATHECT ENGINEERING

**Manufacturer of Circlips, Washers, Dowel Pins, and other Carbon Spring Steel components.**

Cathect Engineering Co. was established in January 2018 and has its manufacturing unit in Vasai, Maharashtra. We manufacture wide range of sheet metal and carbon spring steel components such as Circlips, Washers, Dowel Pins, and other special products as per our customer's requirement.

We manufacture and market our products across India and they find their application in automobiles and are used by many other OEM's.



## Circlips

A circlip (a portmanteau of "circle" and "clip"), also known as a C-clip, Seeger ring, snap ring or Jesus clip is a type of fastener consisting of a semi-flexible metal ring with open ends which can be snapped into place, into a machined groove on a dowel pin or other part to permit rotation but to prevent lateral movement.



## Dowel Pins

A dowel is a cylindrical rod, usually made from wood, plastic, or metal. In its original manufactured form, a dowel is called a dowel rod. Dowel rods are often cut into short lengths called dowel pins. Dowels are commonly used as structural reinforcements in cabinet making and in numerous other applications, including: Furniture shelf supports, Moveable game pieces, Hangers for items such as clothing, key rings, and tools.



## Washers

A washer is a thin plate with a hole (typically in the middle) that is normally used to distribute the load of a threaded fastener, such as a bolt or nut. Other uses are as a spacer, spring (Belleville washer, wave washer), wear pad, preload indicating device, locking device, and to reduce vibration.

## Contact Us

+91 9152559321

+91 9920404201

## Information

mail:sales@cathect.co.in

www.cathect.co.in

Gala No. 6 Agarwal Industrial Eastate ||, Waliv, Vasai East, Dist, PalGhar-401208 Maharashtra, India